

HFR

CF SERIES

High Flow Regulator - 1" Port

Flow Control

For critical applications requiring a fast, accurate control response over a wide range of flows and pressures.

Point of use Regulators

All points of use should be regulated. Otherwise the air saved by regulating the pressure at one point of use will be shunted to some other unregulated point of use and lost as artificial demand. The system balance is upset and potential energy savings are not translated into real dollar savings.

Low Droop

When flow suddenly increases, it can cause larger pressure drops. The variation from the set point is called "droop". These high quality pilot operated regulators are used to stabilize system pressure and provide the best regulation and lower variation in distribution system operating pressures.



- Inline mounting
- Diaphragm type design
- Self relieving
- Pressure gauge (0-200 psig)
- NPTF port Threads (Optional SAE or BSPP Threads)

These pilot operated regulators utilize a small auxiliary regulator to supply the required system pressure to a large diaphragm located on the main line valve that regulates the system pressure. A small change in downstream pressure can effect a large change in the pressure applied to the main regulator diaphragm. The main idea behind the pilot operated pressure regulator valve is the need to open or close the main pressure regulator valve very fast by using additional pressure regulator valve.

Impact RM High Flow Regulators are for critical applications requiring a fast accurate control response over a wide range of flows and pressures. High sensitivity is achieved through a unique spring amplification that accelerates the valve movement. An advanced design pilot controller provides a bias pneumatic signal, negating the need for high internal spring force pressures. This unique arrangement allows Impact RM High Flow Regulators to maintain precise, stable outlet pressures without wasteful pressure differentials stemming from internal mechanical forces. The full capacity of the High Flow Regulator is utilized to control flow instead of becoming a component of the pressure drop across the valve



HFR

CF SERIES

CF- 800

CF-800

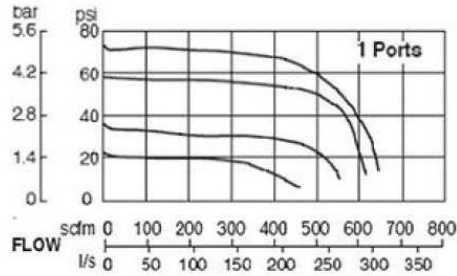

Charts based on 91 PSI inlet. Numbers shown on chart are outlet performances.

SPECIFICATIONS

- Ambient/Media Temperature: 40° to 175° F (4° to 79° C)
- Body: Aluminium
- Dome: Zinc
- Fluid Media: Compressed Air
- Inlet Pressure: 300 psig (21bar) maximum
- Outlet Pressure: 0-200 psig (0-14 bar)
- Pilot Ports: 1/4 NPTF
- Pressure Gauge 0-200 psig (14 Bar)
- Seals: Nitrile
- Valve: Brass
- Valve Cap: Nylon
- Max Temperature: 175° F (79.4 °C)

DIMENSIONS inches (mm)

Ports	A	B	C	Depth	Weight Lb (kg)
1	4.4	4.6	2.4	2.8	4.6
	111	112	62	71	112

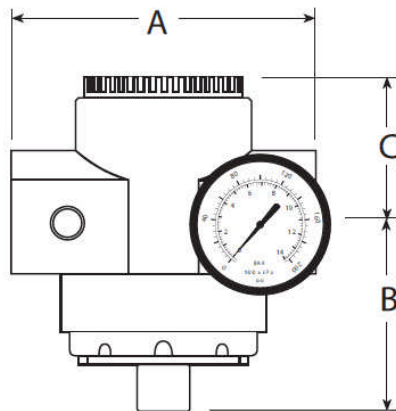

195 Chemin Corbeil
Mont Tremblant, QC J8E 2C1
Phone 819 717-1370
Fax 819 717-1372

Internet: www.impactrm.com