



tyco

Cash Valve

TYPE KP

**PILOT OPERATED
BACK PRESSURE
VALVE**

ISSUED - DECEMBER 2000
CAVMC-0518-US-0208
ISO 9001 Certified

PILOT OPERATED BACK PRESSURE VALVE

KP HIGH CAPACITY PILOT OPERATED BACK PRESSURE VALVE

DESCRIPTION

The Cash Valve Type KP is a pilot operated back pressure valve that offers high capacity and extremely accurate control (see typical flow curve on page 5.) The Type KP automatically maintains the desired maximum pressure in a vessel or system by relieving pressure in excess

of the valve setting into a lower pressure return line or to atmosphere. Type KP valves are not emergency relief devices but are continuous operating valves for water or air systems that offer dependable protection against over pressure conditions.



OPERATION

Initially, both the main valve plug (A) and the pilot valve seat disc (B) are in a closed position. Both will remain closed until the inlet pressure approaches the pressure setting of the valve.

When pressure is introduced at the inlet of the main valve it is also directed through the copper tube (C) to the pilot valve diaphragm chamber (D). The pressure required to open the pilot valve seat disc (B) is determined by the pressure setting of the pilot spring (E). When the inlet pressure in the diaphragm chamber (D) is greater than the pressure setting, the seat disc (B) opens. Pressure then passes from the pilot valve diaphragm chamber (D) through the seat ring and into the main valve diaphragm chamber (F). Pressure also passes through the seat disc orifice (K) into the pilot valve spring chamber (G), where it is vented downstream through the pilot valve orifice (H) and the copper tube (I), (or to atmosphere in air service where normally no tube is required). When pressure in the main valve diaphragm chamber (F) exceeds the upward force of the main valve piston spring (J), the main valve plug (A) opens and allows flow through the valve.

When the inlet pressure drops below the pressure setting of the valve, the pilot spring (E) forces the seat disc (B) to close. Pressure in the main valve diaphragm chamber (F) now bleeds through the seat disc orifice (K) into the spring chamber (G) and then downstream on water valves or into the atmosphere on air models. As pressure drops in the main valve diaphragm chamber (F), the main

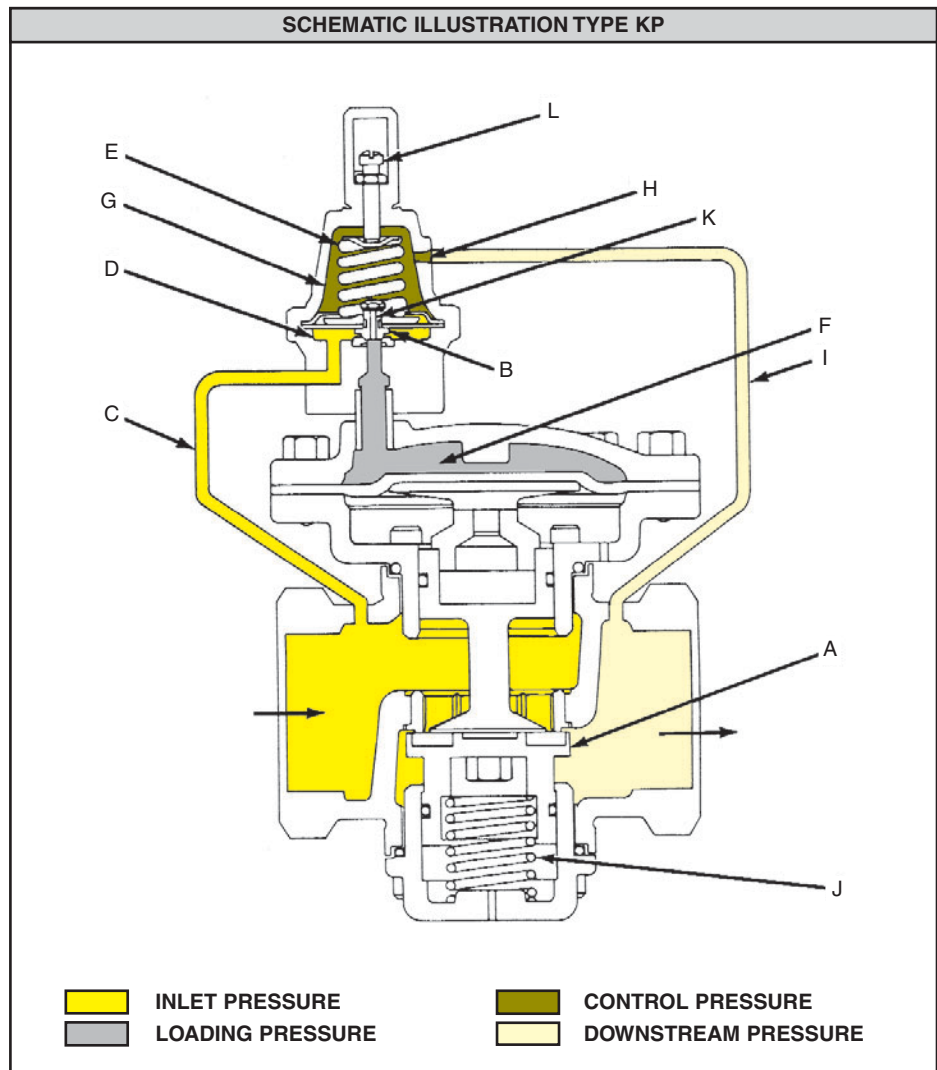

valve piston spring (J) forces the main valve plug (A) to close. Since the seat is a rubber material, the valve is now tightly shut off.

In normal operation the Pilot Valve modulates the pressure in Diaphragm Chamber (F) to control the main valve plug (A) opening to regulate the fluid flow and maintain the pressure control on the system under varying pressure and flow conditions.

APPLICATION

The Type KP back pressure regulator is intended for service on water or air. For service other than water or air, consult the factory for recommendations. The Type KP is designed for systems which require pressure control to 200 psi and having temperatures to 160°F. DO NOT USE high temperature version on water applications that will flash to steam on the downstream side of the valve. The Type KP is also available with factory modifications for

high temperature to 400°F, high pressure to 400 psi. Consult the factory for additional information.

The KP water valve has an inlet pressure connection to the pilot valve as well as a connection from the pilot valve's upper spring chamber to the valve outlet or downstream line. A fixed bleed orifice in the pilot valve spring chamber allows water pressure from the upper spring chamber to bleed

downstream. Downstream pressure in excess of 5 psi could, however, affect valve performance. If the downstream pressure exceeds 5 psi, the pilot bleed line should be piped to an open drain rather than into the downstream line.

The KP air model is similar to the water valve with the exception that the pressure in the spring chamber bleeds directly to atmosphere rather than to the downstream line.

FEATURES

- Available in 1", 1^{1/4}", 1^{1/2}", and 2" sizes with threaded connections.
- Designed to be installed in any system where back pressure valves are required and accurate control must be maintained, especially when high capacity flows are required.
- Soft rubber seat allows the valve to shut off tight under no-flow conditions.
- Available with factory modifications for systems with high temperatures (to 400°F), high pressure (to 400 psi).
- Easily serviced, pilot system can be removed as one unit.
- Two adjustment ranges are available: 15-65 psi and 50-200 psi. A special Hi-Pressure range from 200-400 psi is also available.
- Maximum overpressure on standard spring ranges is up to 300 psi and 500 psi on the Hi-Pressure range.

PILOT OPERATED BACK PRESSURE VALVE

CONSTRUCTION

The Type KP main valve is fitted with a brass body, diaphragm case and stem; Buna-N diaphragm and seat disc, and a

stainless steel spring. The pilot valve has a brass body and spring chamber; a stainless steel spring, seat disc and seat

ring; and bronze diaphragms for air service or a Neoprene diaphragm for water applications.

TYPICAL INSTALLATIONS

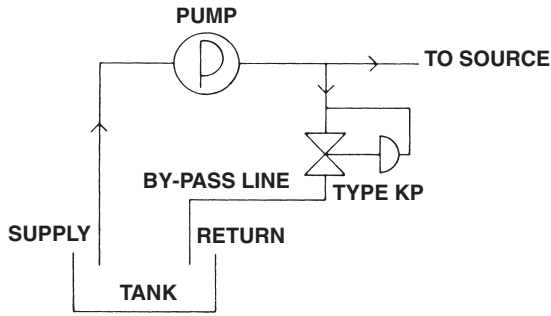

PUMP BY-PASS - Type KP will serve as a highly accurate, high capacity pump by-pass valve.

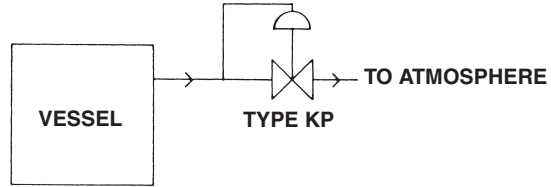

BACK PRESSURE RELIEF - The KP can be used as an in-line back pressure relief valve where both accuracy and high capacity are required.

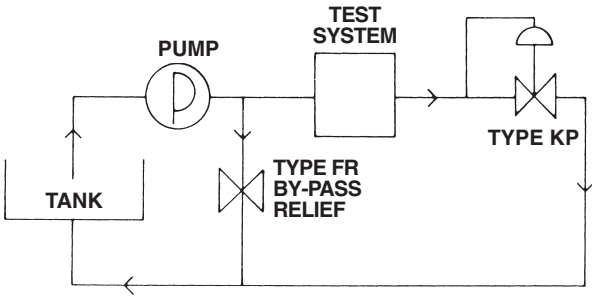

TEST SYSTEM BY-PASS - an FR or similar Cash Valve by-pass valve would function as a by-pass pressure control while the KP would be used as an in-line back pressure control to maintain the discharge pressure of a system.

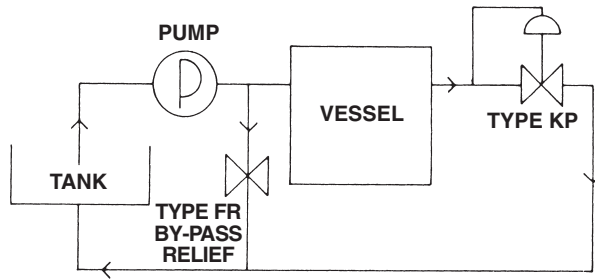

PRESSURE VESSEL CONTROL - In this example, a standard Cash Valve back pressure valve would serve as a by-pass pressure valve and the KP would control the outlet pressure from a vessel or container.

PILOT OPERATED BACK PRESSURE VALVE

SPECIFICATIONS

VALVE SIZE	SPRING NUMBER	RANGE OF ADJUSTMENT (psi)	MAXIMUM VALVE OVERPRESSURE*
All Sizes	4765	15-65	100 psi
	7337	50-200	300 psi

NOTE: Type KP is also available for pressure settings from 200 to 300 psi; consult factory for details.

* Maximum valve overpressure is defined as the maximum pressure a valve can sustain without internal damage.

SIZE	SERVICE	DIMENSIONS				SHIPPING WEIGHT (lbs.)
		A	B	C	D	
1"	Air	6 ³ / ₄ "	2 ⁷ / ₈ "	3 ¹ / ₈ "	4 ¹ / ₂ "	8 ¹ / ₄
	Water	7 ⁷ / ₈ "	2 ⁷ / ₈ "	3 ¹ / ₂ "	4 ¹ / ₂ "	8 ³ / ₄
1 ¹ / ₄ "	Air	6 ³ / ₄ "	2 ⁷ / ₈ "	3 ¹ / ₈ "	4 ¹ / ₂ "	8 ¹ / ₄
	Water	7 ⁷ / ₈ "	2 ⁷ / ₈ "	3 ¹ / ₂ "	4 ¹ / ₂ "	8 ³ / ₄
1 ¹ / ₂ "	Air	7 ¹ / ₄ "	2 ¹⁵ / ₁₆ "	3 ¹⁵ / ₁₆ "	5 ³ / ₄ "	20 ¹ / ₄
	Water	8 ³ / ₈ "	2 ¹⁵ / ₁₆ "	3 ¹⁵ / ₁₆ "	5 ³ / ₄ "	20 ³ / ₄
2"	Air	7 ¹ / ₄ "	2 ¹⁵ / ₁₆ "	3 ¹⁵ / ₁₆ "	5 ³ / ₄ "	20 ¹ / ₄
	Water	8 ³ / ₈ "	2 ¹⁵ / ₁₆ "	3 ¹⁵ / ₁₆ "	5 ³ / ₄ "	20 ³ / ₄

TYPICAL PERFORMANCE

The Performance curves shown are for a 2" Type KP for water service at pressure settings of 75, 100 and 150 psi. These flow curves clearly show the exceptional control offered by the Type KP; there

CURVES

is very little change in pressure from minimum to maximum flow. For example, a 2" KP with a 100 psi pressure setting will pass 120 gpm with only a 5% rise in pressure (to 105 psi).

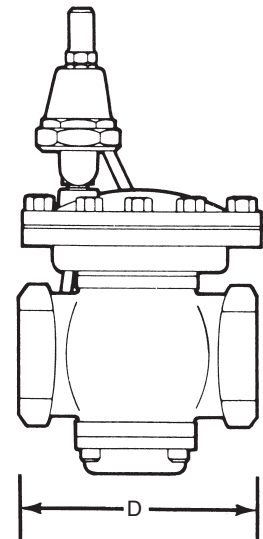
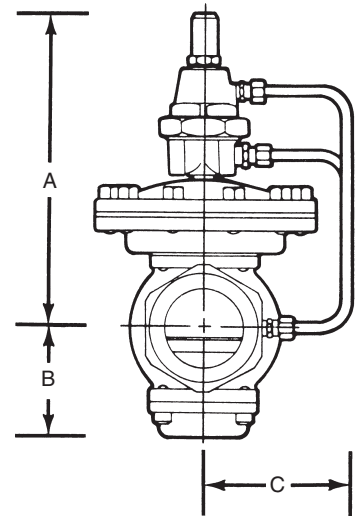
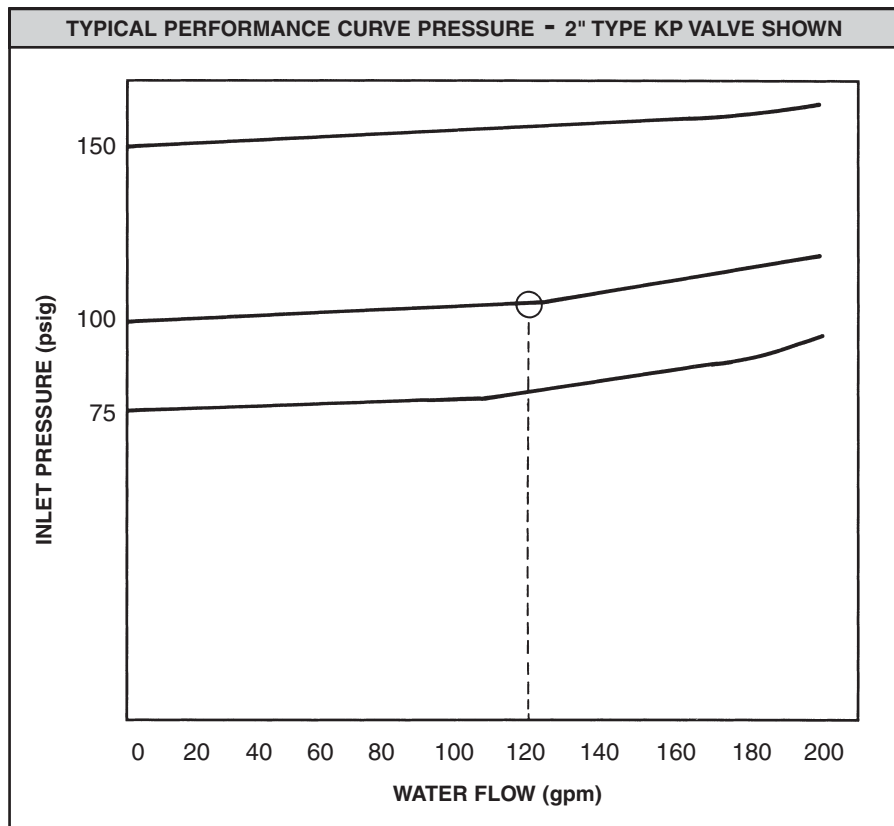

CONTINUED ON NEXT PAGE >

PILOT OPERATED BACK PRESSURE VALVE

SPECIFICATIONS (Continued)

CAPACITY INFORMATION									
INLET PRESSURE (psi)	INLET PRESSURE RISE*	WATER FLOW (gpm)				AIR FLOW (scfm)			
		1"	1 1/4"	1 1/2"	2"	1"	1 1/4"	1 1/2"	2"
15	5%	25	25	45	45	162	180	500	560
	10%	30	35	60	60	182	200	540	600
	20%	35	50	95	95	210	235	575	640
25	5%	35	35	60	60	225	250	735	820
	10%	40	50	80	80	265	295	800	890
	20%	40	70	125	125	295	330	890	990
50	5%	40	60	85	85	405	450	1260	1400
	10%	50	70	105	105	435	485	1300	1450
	20%	50	90	130	155	460	515	1365	1520
75	5%	50	70	100	100	540	600	1590	1770
	10%	50	90	125	125	550	610	1635	1820
	20%	50	90	130	180	575	640	1710	1900
100	5%	50	90	120	120	615	685	1820	2020
	10%	50	90	130	150	635	707	1890	2100
	20%	50	90	130	210	660	735	1980	2200
125	5%	50	90	130	135	688	765	2030	2260
	10%	50	90	130	180	710	790	2125	2360
	20%	50	90	130	210	745	830	2215	2460
150	5%	50	90	130	160	760	845	2250	2500
	10%	50	90	130	210	780	870	2320	2580
	20%	50	90	130	210	815	905	2410	2680
200	5%	50	90	130	200	855	950	2565	2850
	10%	50	90	130	210	875	975	2610	2900
	20%	50	90	130	210	920	1020	2700	3010

Note: Flows are based on valve discharge to atmosphere or to an atmospheric pressure return line. If the valve discharge pressure is higher than 5 psi, consult the factory for capacity information.

* Inlet pressure rise is defined as the increase in inlet pressure required to pass a given flow, shown here as a percentage. For example: What size KP valve would be required to pass 70 gpm at a set pressure of 50 psi and a maximum allowable overpressure to 55 psi (10% rise)? The proper valve selection, based on the above table, would be a 1 1/4" KP valve.

HOW TO ORDER

To order, specify Cash Valve type by specific series designation (i.e. Type KP). Also state the following:

1. Valve size
2. Service (water, air, oil, etc.)
3. Set pressure and pressure range
4. Maximum required flow rate
5. System operating temperature

Cash Valve
 953 Old U.S. Highway 70
 Black Mountain, NC 28771
 Phone: 800-879-2042 • 828-669-3710
 Fax: 800-879-2057 • 828-669-0586
 CAVMC-0518-US-0208

Tyco Valves & Controls
www.cashvalve.com