

COMPRESSED AIR COOLING | Air AA Series

COPPER TUBE CONSTRUCTION

Features

- Full Line of Sizes and Features
- Energy Efficient
- High Performance
- Medium Flows 80-300 CFM
- Horizontal Air Flow
- Optional Weatherproof Junction Box
- Floor or Suspended Mounting
- Optional TEFC motor(s)
- Ratings Based on Comprehensive Testing
- Wired for Single Point External Connection

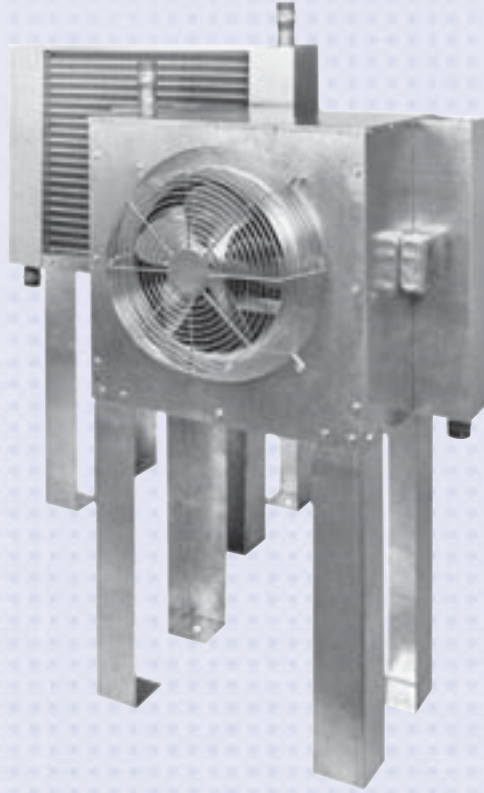

Ratings

Maximum Operating Pressure 250 psig

Maximum Operating Temperature 350° F

Materials

Cabinet Galvanized Steel

Core Aluminum Fins on Copper Tubes

Fan Heave Gauge Aluminum with Steel Hub

Motor Open Vented

Fan Guard Steel with Baked Enamel Finish

AIR COOLED AA

How to Order

AA	-	<input type="text"/>	-	<input type="text"/>
Model Series AA		Model Size Selected		Specify Motor Required 0 - No Motor 1 - Single Phase 60 Hz ODP 115 Volt 2 - Single Phase 60 Hz TEFC 115/208-230 Volt 3 - Three Phase 60 Hz TEFC 208-230/460 Volt 5 - Air Motor

Dimensions

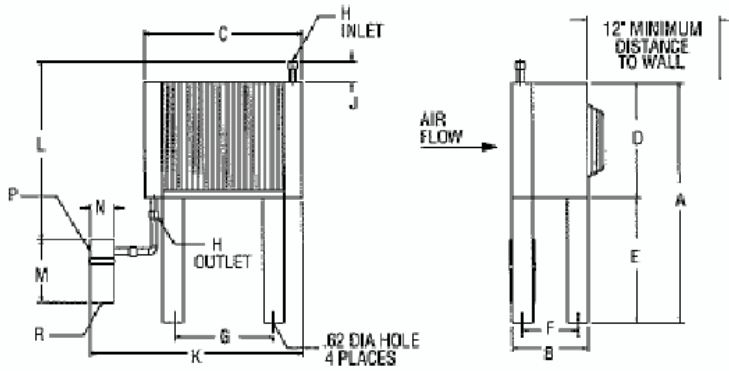

Model	A	B	C	D Approx	E	F	G	H NPT	J	K* Approx	L* Approx	Optional Separator				Recommended Optional Separator Model Number
												M	N	NPT	R	
AA-50	46.50	14.75	30.50	22.50	24.00	10.75	19.09	1.00	4.00	41.12	34.50	10.00	4.62	1	1/4	S-100M or AD
AA-80			35.00					1.50			37.10					
AA-120			43.50	2.00			36.60	12.10		4.70	1					
AA-150			47.63	25.50			36.09					1-1/2	S-200M			
AA-240	49.50	51.68	31.50	62.38	49.60	S-300M										

Note: We reserve the right to make reasonable design changes without notice. All Dimensions are in inches.

Capacity Selection Chart Max. SCFM @ 5, 10, 15 and 20°F Approach

Inlet Temp. °F	150				200				250				300				350				Recommended Optional Separator Model Number	
	Approach Temp. °F	5	10	15	20	5	10	15	20	5	10	15	20	5	10	15	20	5	10	15		20
Model Number	AA-50	34	58	79	99	25	43	59	74	21	36	50	62	18	31	42	52	16	27	38	47	S-100M or AD
	AA-80	50	87	119	150	40	69	94	117	34	59	80	100	30	52	71	89	28	47	65	82	
	AA-120	81	138	190	235	61	105	142	177	51	87	120	150	43	75	102	127	40	69	94	116	S-200M
	AA-150	92	160	220	270	73	125	172	215	63	110	150	187	55	95	130	160	50	86	120	148	
	AA-240	160	275	380	425*	120	207	285	355	100	175	240	300	84	145	204	250	78	135	185	231	
	AA-300	184	318	440	480*	145	250	345	430	125	217	300	375	110	190	257	320	100	175	240	300	

Above specifications are based on 80 to 125 PSIG operating pressures.

Maximum pressure drop, less than 3 psi. A flexible metal hose must be properly installed between the compressor and aftercooler to validate warranty.

*Maximum ratings restricted by pressure drop, actual thermal capacities are higher.

Electric Motor & Fan Data

Model	CFM	Motor H.P.	Standard Motor (ODP)		Optional Motor (TEFC)		Optional Motor (TEFC)*		Optional Air Motor		Approx. Shipping Overload (Lbs.)
			Voltage	Full Load Amps/Motor	Voltage	Full Load Amps/Motor	Voltage	Full Load Amps/Motor	PSI ⁽¹⁾	CFM ⁽²⁾	
AA-50	1375	1/4	115/1/60	7.2	115/208 230/1/60	5/2.6-2.5	208-230/ 460/3/60	1.4-1.3/65	50	13	110
AA-80											120
AA-120	2450										140
AA-150	2350										145
AA-240	4600	1/4 ⁽²⁾									200
AA-300	4700										300

Standard Motor(s) = 1600 RPM, Custom Frame, Equipped with Thermal Overload. Optional Motor(s) = 1725 RPM, Nema 48 Frame, No Thermal Overload.

Published electrical ratings are approximate, and may vary because of motor brand. Actual ratings are on motor nameplate.

***3 phase motors available in 50Hz. Reduce performance by 10%**

(1) Air inlet to motor must be regulated to this pressure.

(2) CFM (Free Air) consumption of the air motor. Lubrication = one drop of oil for every 50-75 CFM of air going through the motor. Use detergent SAE #10 oil. Filter, regulator and lubricators for the air motors are required, but not included.