

Description		Assembly Order No.
Style 7002	Blind nut, 1/8 NPT	WO2-358-7002
Two Ply Bellows		
Assembly weight		1.8 lbs.

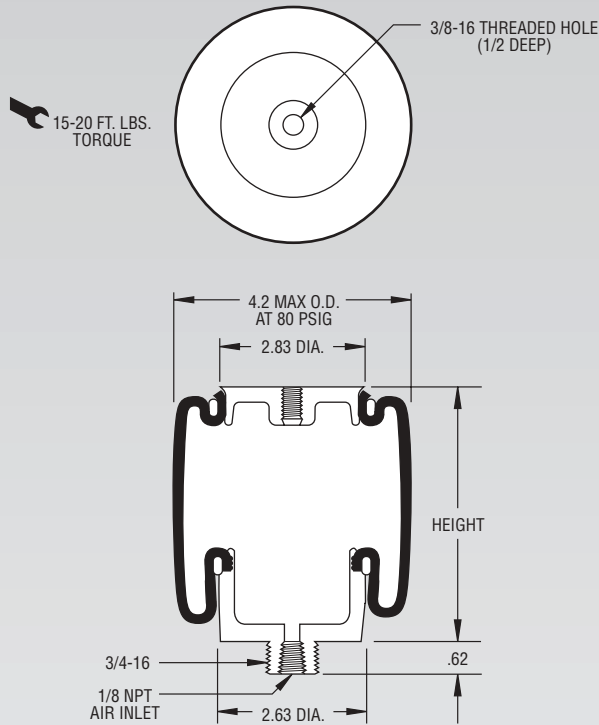

NOTE: Bellows will not compress properly with less than 10 PSIG internal pressure.

CONSULT FIRESTONE BEFORE USING AS AIRMOUNT

RECOMMENDED AIRMOUNT DESIGN HEIGHT 4.5 INCHES

Static Data
8609

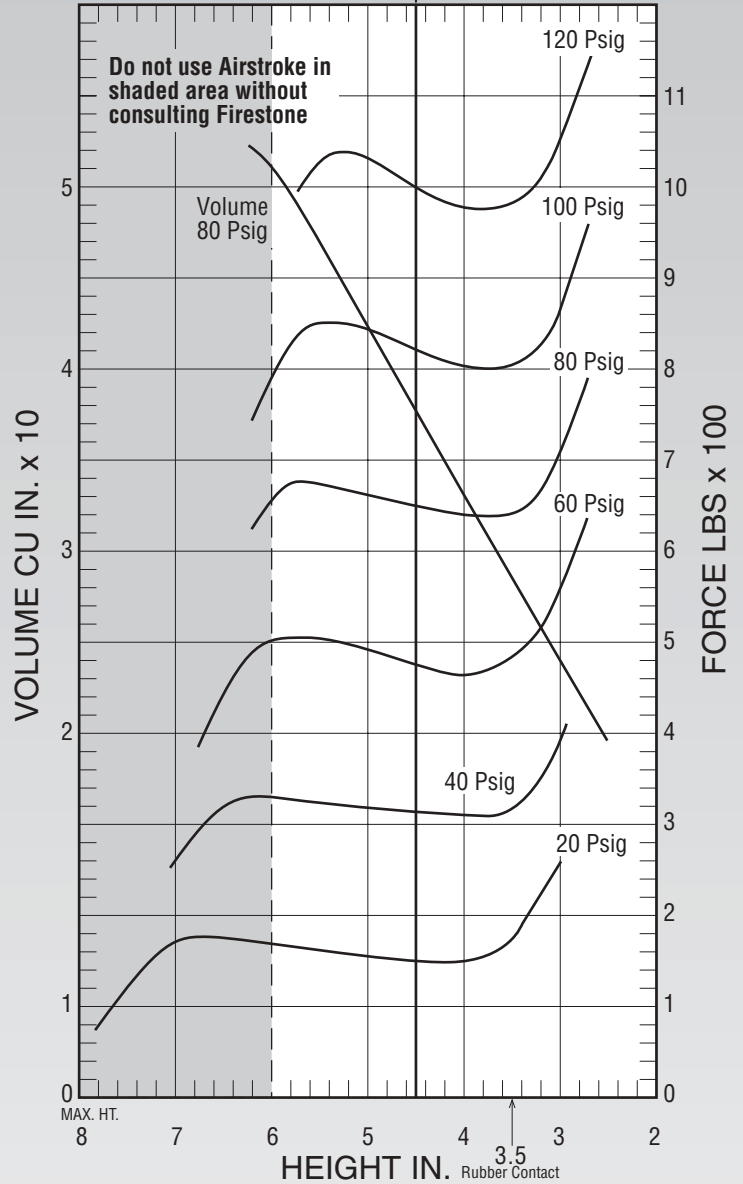

See page 12 for instructions on how to use chart.

Dynamic Characteristics at 4.5 in. Design Height (Required for Airmount isolator design only)				
Volume @ 80 PSIG = 37 in ³			Natural Frequency	
Gage Pressure (PSIG)	Load (lbs.)	Spring Rate (lbs./in.)	CPM	HZ
40	310	137	124	2.07
60	480	178	114	1.91
80	650	239	114	1.89
100	820	280	110	1.81

Force Table (Use for Airstroke® actuator design)						
Assembly Height (in.)	Volume @ 80 PSIG (in ³)	Pounds Force				
		@20 PSIG	@40 PSIG	@60 PSIG	@80 PSIG	@100 PSIG
6.0	50	170	330	510	680	860
5.0	42	150	320	490	660	840
4.0	33	150	310	470	640	800