

BLOWING GUNS WITH ADJUSTABLE HOSE



REPLACES BLOWING GUNS WITHOUT NOZZLES

With blowing pipe diameters 3 - 4 mm
1/8"

BENEFITS

- Noise reduction – Halves the noise level
- Air consumption reduction – 20 - 40%
- Safety nozzle – Meets OSHA standards

The Silvent FLEXGUN is fitted with a bendable hose that can be adjusted to any position. The hose will not wander, even when blowing at high pressures. Excellent for blowing deep inside machines or motors in areas that are inaccessible with conventional blowing methods. Highly recommended for blowing opera-

tions that are hard to reach or directly hazardous to the operator. Silvent's FLEXGUN allows you to perform those "hard-to-reach" operations without risking injury to eyes or hands from flying chips or moving parts. FLEXGUN is available in six standard lengths. Meets OSHA safety regulations. Patented.



DIMENSIONS

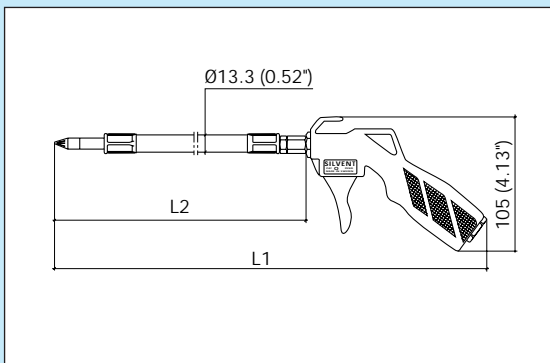

AIR CONE PATTERN

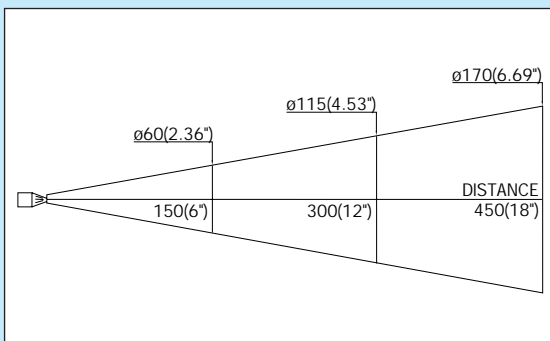

PRODUCT INFORMATION

ORDER NO./ MODEL	520	530	540	550	560	580	
Nozzle	5001	5001	5001	5001	5001	5001	
L1	mm	340	440	540	640	740	940
	"	13.39	17.32	21.26	25.20	29.13	37.01
L2	mm	200	300	400	500	600	800
	"	7.87	11.81	15.75	19.69	23.62	31.50

Replaces open pipe	mm	4	4	4	4	4	4
	"	1/8	1/8	1/8	1/8	1/8	1/8
Air consumption	Nm ³ /h	16.0	16.0	16.0	16.0	16.0	16.0
	scfm	9.4	9.4	9.4	9.4	9.4	9.4
Sound level	dB(A)	79	79	79	79	79	79
Blowing force	N	2.9	2.9	2.9	2.9	2.9	2.9
	oz	10.2	10.2	10.2	10.2	10.2	10.2
Max. temp.	°C	-20/+70	-20/+70	-20/+70	-20/+70	-20/+70	-20/+70
	°F	-4/+158	-4/+158	-4/+158	-4/+158	-4/+158	-4/+158
Weight	g	195	220	245	270	295	345
	lbs	0.43	0.48	0.54	0.59	0.65	0.76
Connection	BSP	1/4"	1/4"	1/4"	1/4"	1/4"	1/4"
	NPT	1/4"-18	1/4"-18	1/4"-18	1/4"-18	1/4"-18	1/4"-18
Nozzle material	Zinc						

Further information in: Technical specifications.

Max. operating pressure: 1.0 MPa (143 psi)