

DOUGHNUT NOZZLES



REPLACE OPEN PIPE OF DIAMETERS:



12 - 16 mm

1/2" - 5/8"

BENEFITS

Reduces the noise level 15 - 19 dB(A)

Decreases air consumption 36 - 52 %

Safety nozzle Meets OSHA standards

The Silvent 462 is a doughnut nozzle for effective drying or cleaning of cables, profiles, hoses, etc. Its design allows the material to be continuously fed through the nozzle. Blow-off is accomplished by 12 concentrated air jets that strike the material from all sides as it passes. The nozzle is suitable for cables and profiles of from \varnothing 25 to 80 mm (1"-3 3/16"). Patented.

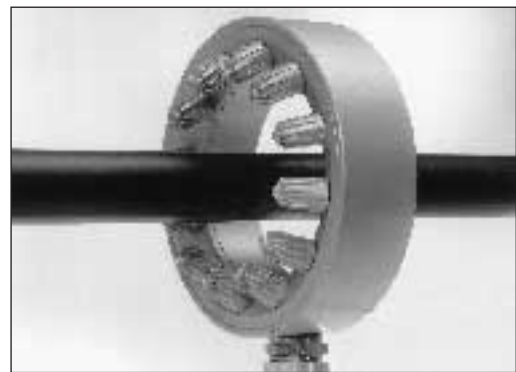

In this application a \varnothing 38 mm (1.5") hose is blown clean and dry by the 462.

DIMENSIONS

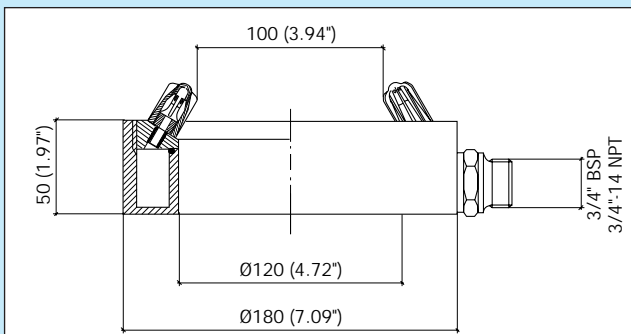

AIR CONE PATTERN

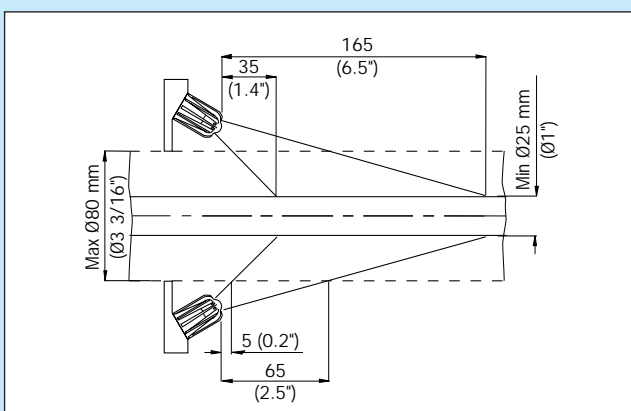

PRODUCT INFORMATION

ORDER NO./MODEL	462	
Replaces open pipe	mm	16
	"	5/8
Air consumption	Nm ³ /h	228
	scfm	134.3
Sound level	dB(A)	94
Blowing force	N	40
	oz	141.1
Max. temp.	°C	-20/+70
	°F	-4/+158
Weight	g	1400
	lbs	3.08
Nozzle material	Zinc	

Further information in: Technical specifications.

Max. operating pressure: 1.0 MPa (143 psi)