

DOUGHNUT NOZZLES



REPLACE OPEN PIPE OF DIAMETERS:



7 - 10 mm

1/4" - 3/8"

BENEFITS

Reduces the noise level 15 - 21 dB(A)

Decreases air consumption 21 - 35 %

Safety nozzle Meets OSHA standards



The picture shows a Silvent 456 doughnut nozzle drying cable in continuous production.

The Silvent 456 is a doughnut nozzle for effective drying or cleaning of cables, profiles, hoses, etc. Its design allows the material to be continuously fed through the nozzle. Blow-off is accomplished by 6 concentrated air jets that strike the material from all sides as it passes. The nozzle is suitable for cables and profiles of from Ø 5 to 25 mm (3/16"-1"). Patented.

DIMENSIONS

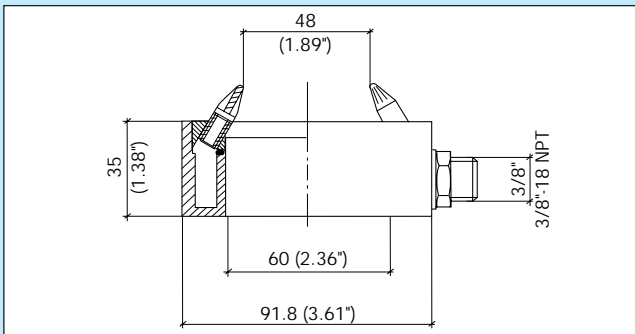

AIR CONE PATTERN

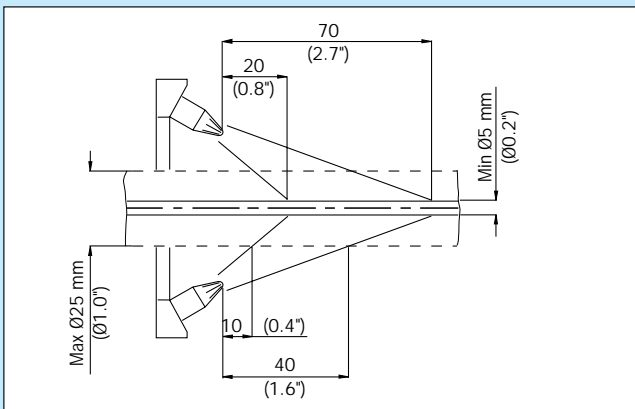

PRODUCT INFORMATION

ORDER NO./MODEL	456	
Replaces open pipe	mm	10
	"	3/8
Air consumption	Nm ³ /h	114
	scfm	67.2
Sound level	dB(A)	90
Blowing force	N	20
	oz	70.5
Max. temp.	°C	-20/+70
	°F	-4/+158
Weight	g	260
	lbs	0.57
Nozzle material	Zinc	

Further information in: Technical specifications.

Max. operating pressure: 1.0 MPa (143 psi)