

Description		Assembly Order No.
Style 352	Blind nuts, 1/4 NPT	WO1-358-8048
	Blind nuts, 3/4 NPT	WO1-358-8047
Two Ply Bellows		
Assembly weight.....		20.3 lbs.
Force to collapse to minimum height (@ 0 PSIG).....		21 lbs.

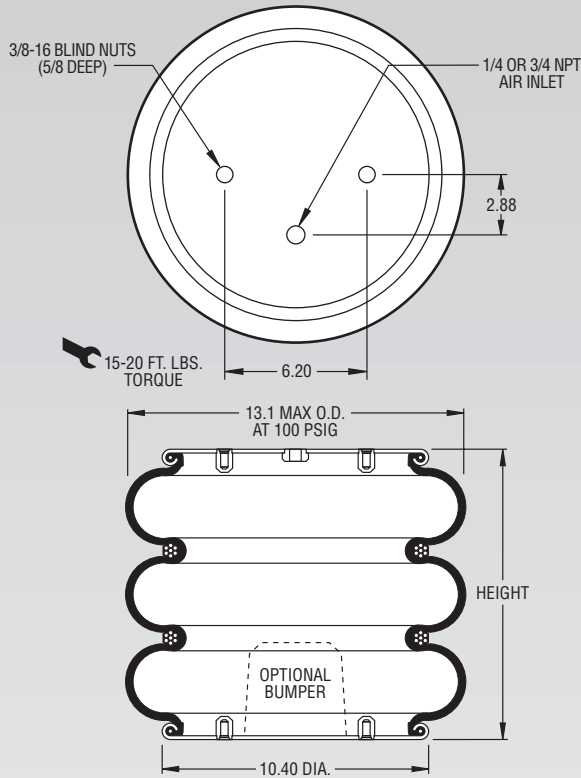

NOTE: A bead plate part is shown. This part is also available with bead rings. See pages 8-10 for explanation.

Dynamic Characteristics at 13.5 in. Design Height (Required for Airmount isolator design only)				
Volume @ 100 PSIG = 1,168 in ³			Natural Frequency	
Gage Pressure (PSIG)	Load (lbs.)	Spring Rate (lbs./in.)	CPM	HZ
40	2,319	475	85	1.42
60	3,631	675	81	1.35
80	5,017	851	77	1.29
100	6,463	1,042	75	1.26

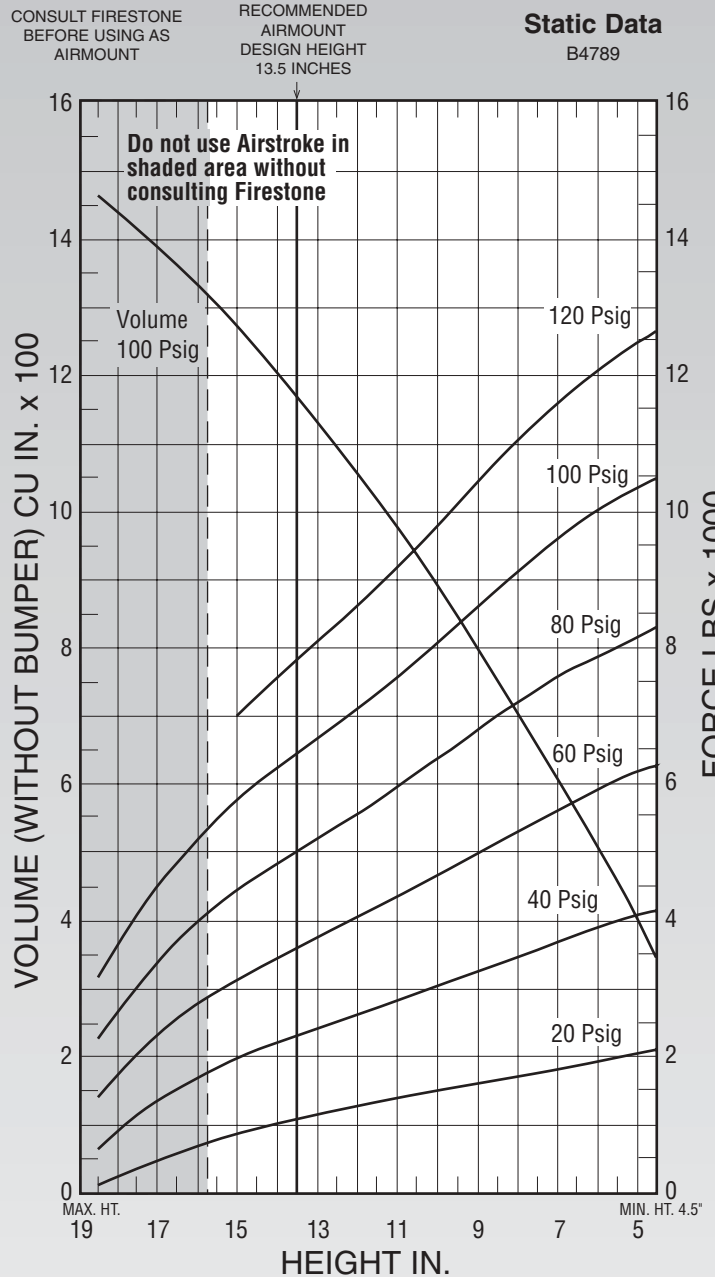

See page 12 for instructions on how to use chart.

Force Table (Use for Airstroke® actuator design)						
Assembly Height (in.)	Volume @ 100 PSIG (in ³)	Pounds Force				
		@20 PSIG	@40 PSIG	@60 PSIG	@80 PSIG	@100 PSIG
16.0	1,330	679	1,695	2,780	4,000	5,221
14.0	1,203	1,015	2,211	3,480	4,838	6,248
12.0	1,057	1,278	2,622	4,068	5,557	7,104
10.0	892	1,497	3,025	4,662	6,365	8,069
8.0	708	1,700	3,457	5,296	7,201	9,127
6.0	507	1,917	3,896	5,910	7,881	10,030
5.0	400	2,040	4,095	6,169	8,165	10,363