

Description		Assembly Order No.
Style 255-1.5	Blind nuts, 1/4 NPT	WO1-358-6955
	Blind nuts, 3/4 NPT	WO1-358-6956
Two Ply Bellows	Rubber bellows only	WO1-358-0048
	Socket head aluminum bead rings (bolts, nuts, washers not included, use cap screws)	WO1-358-6833
Assembly weight .....		3.9 lbs.
Force to collapse to minimum height (@ 0 PSIG).....		50 lbs.

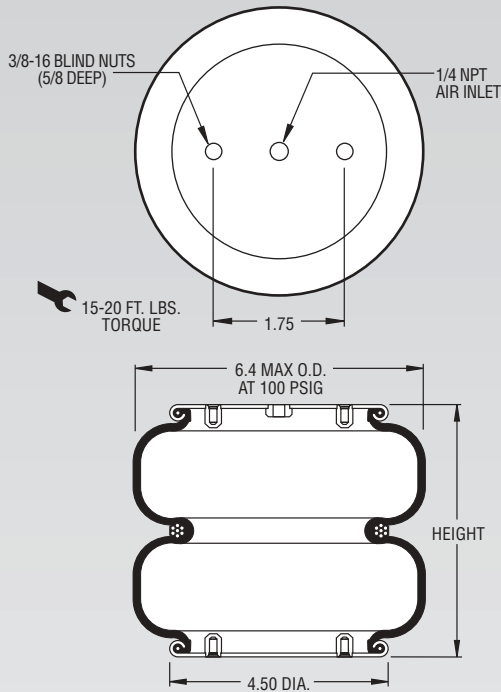

**NOTE: A bead plate part is shown. This part is also available with bead rings. Bolts are not included. See pages 8-10 for explanation.**

Dynamic Characteristics at 6.0 in. Design Height (Required for Airmount isolator design only)				
Volume @ 100 PSIG = 100 in <sup>3</sup>			Natural Frequency	
Gage Pressure (PSIG)	Load (lbs.)	Spring Rate (lbs./in.)	CPM	HZ
40	566	309	139	2.32
60	871	432	132	2.21
80	1,194	565	129	2.16
100	1,524	681	126	2.10

CONSULT FIRESTONE BEFORE USING AS AIRMOUNT

RECOMMENDED AIRMOUNT DESIGN HEIGHT 6.0 INCHES

**Static Data**  
B4652

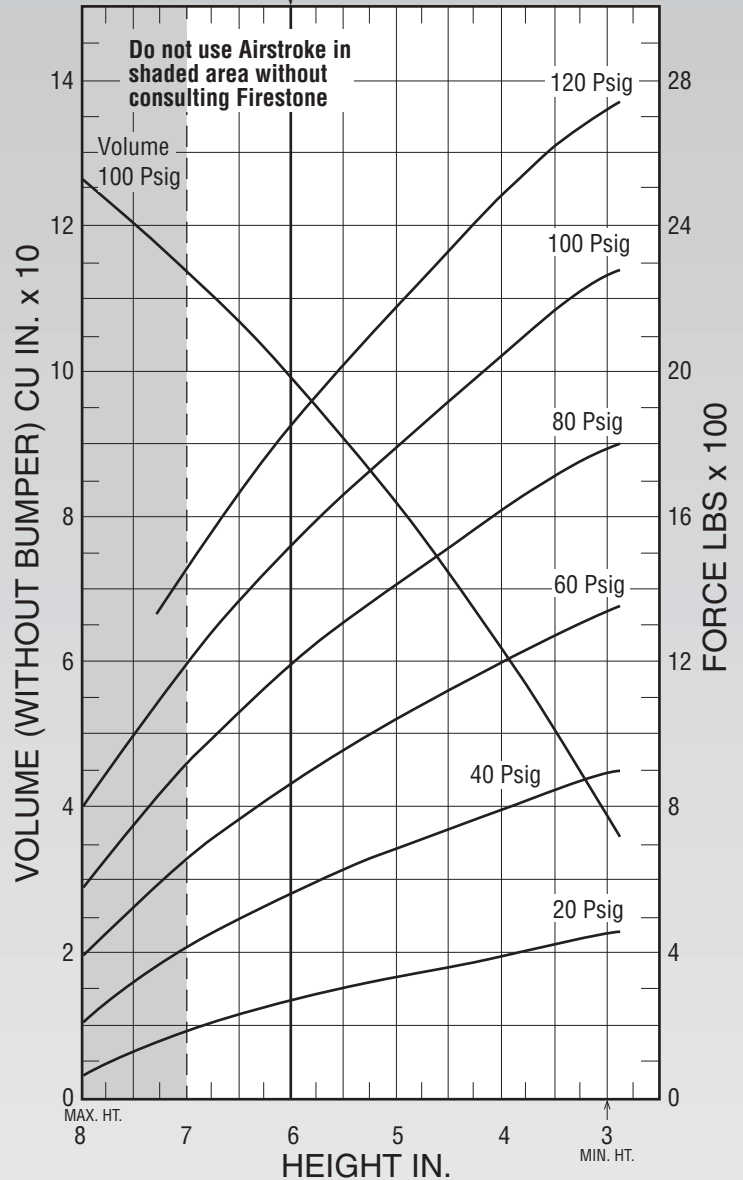

See page 12 for instructions on how to use chart.

Force Table (Use for Airstroke® actuator design)						
Assembly Height (in.)	Volume @ 100 PSIG (in <sup>3</sup> )	Pounds Force				
		@20 PSIG	@40 PSIG	@60 PSIG	@80 PSIG	@100 PSIG
7.0	114	188	417	661	921	1,198
6.0	100	270	566	871	1,194	1,524
5.0	82	331	686	1,041	1,414	1,786
4.0	62	389	729	1,197	1,612	2,039