

Description		Assembly Order No.
Style 248-2	Ribbed neck aluminum bead rings (equal spacing), 1 7/8 bolts, nuts, washers	WO1-358-9602
Four Ply Bellows		
Assembly weight .....		72.5 lbs.
Force to collapse to minimum height (@ 0 PSIG)....		350 lbs.

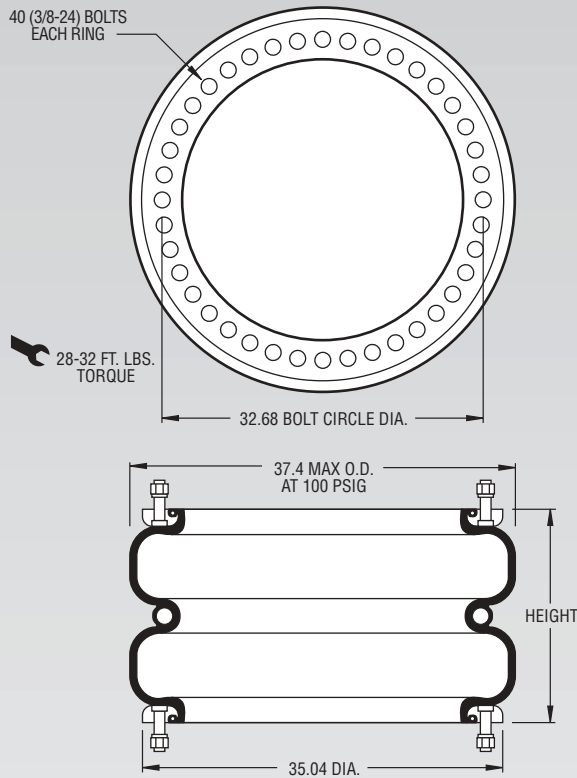

**NOTE:** The effective length of 1 7/8 bolt is 1.05" in this bead ring.

Dynamic Characteristics at 11.0 in. Design Height (Required for Airmount isolator design only)				
Volume @ 100 PSIG = 9,815 in <sup>3</sup>			Natural Frequency	
Gage Pressure (PSIG)	Load (lbs.)	Spring Rate (lbs./in.)	CPM	HZ
40	30,830	6,746	88	1.46
60	47,720	9,549	84	1.40
80	63,890	12,423	83	1.38
100	79,730	14,989	81	1.36

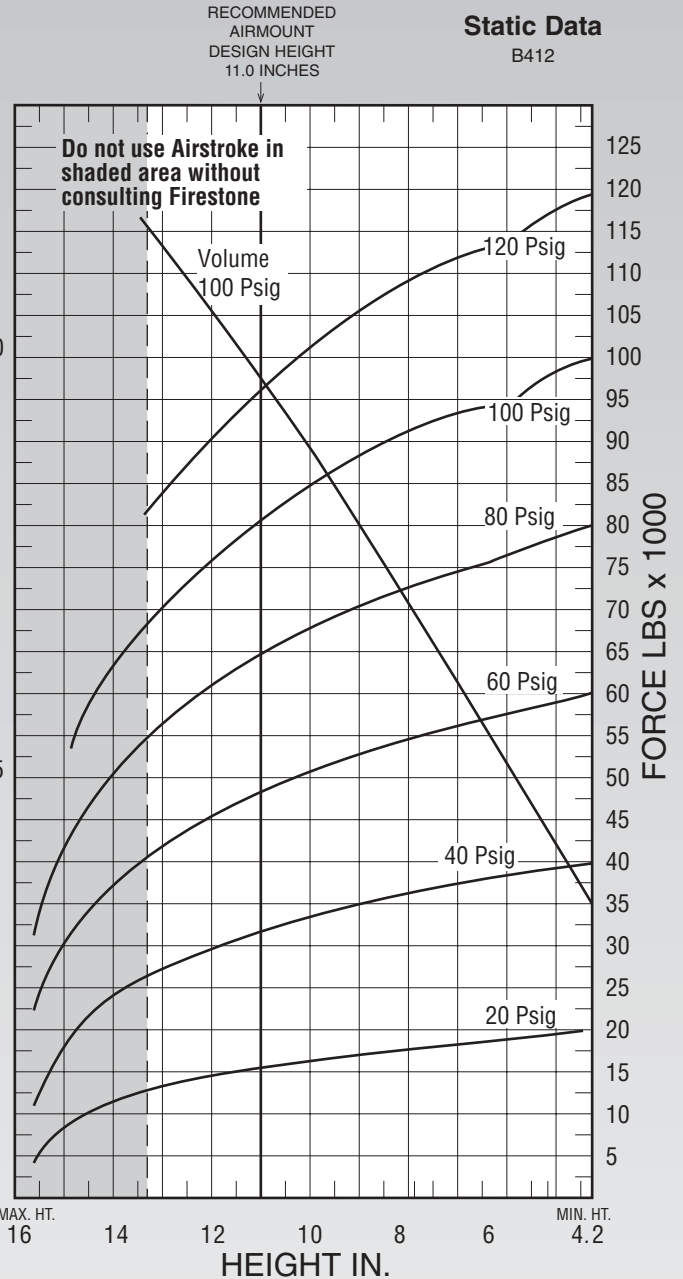

See page 12 for instructions on how to use chart.

Force Table (Use for Airstroke <sup>®</sup> actuator design)						
Assembly Height (in.)	Volume @ 100 PSIG (in <sup>3</sup> )	Pounds Force				
		@20 PSIG	@40 PSIG	@60 PSIG	@80 PSIG	@100 PSIG
13.0	11,386	12,660	26,460	41,020	55,290	69,700
11.0	9,815	15,200	30,830	47,720	63,890	79,730
9.0	8,090	16,890	34,210	52,080	69,850	87,790
7.0	6,243	18,210	37,030	55,570	74,410	93,230
5.0	4,304	19,270	38,820	58,730	78,570	98,180