

Description		Assembly Order No.
Style 215	Ribbed neck aluminum bead rings (equal spacing), 1 7/8 bolts, nuts, washers	WO1-358-7230
Two Ply High Strength Bellows	Ribbed neck aluminum bead rings (unequal spacing) 1 7/8 b,n,w	WO1-358-7301
	Ribbed neck aluminum bead rings (equal spacing) 1 1/4 b,n,w	WO1-358-7302
	Rubber bellows only	WO1-358-7912
Assembly weight		38.4 lbs.
Force to collapse to minimum height (@ 0 PSIG)....		160 lbs.

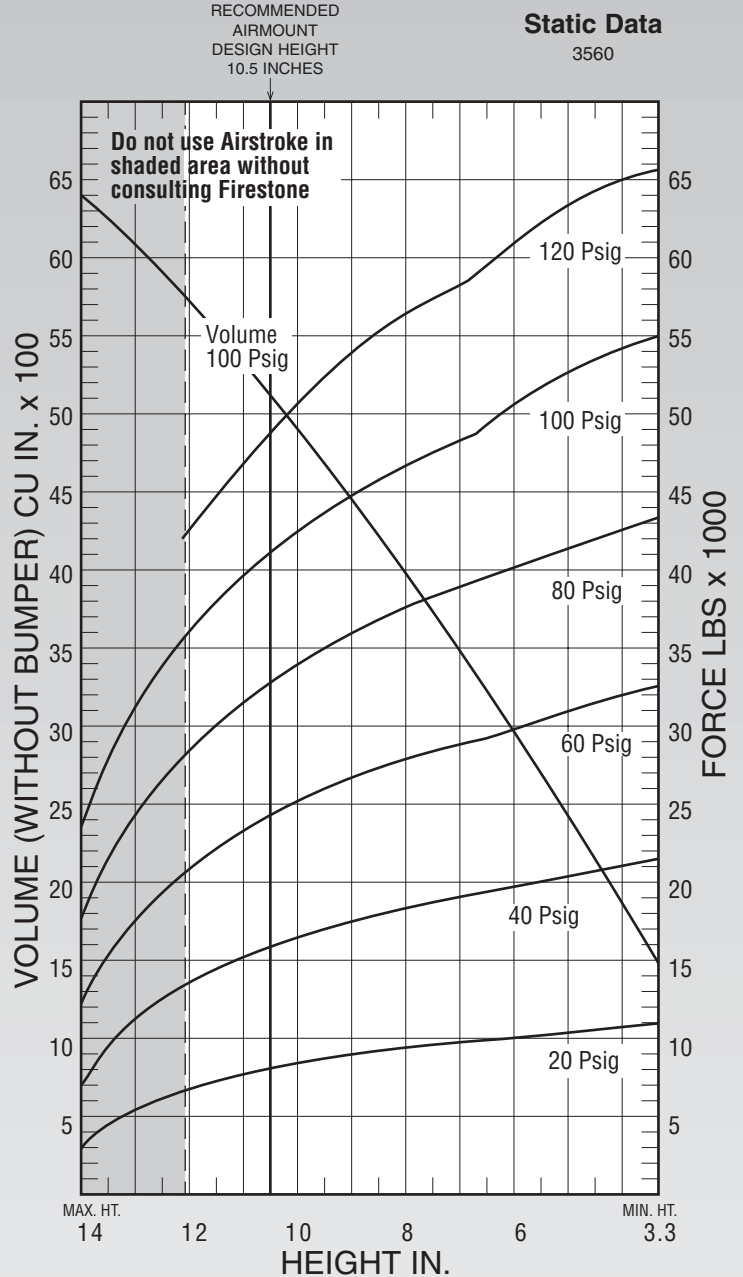
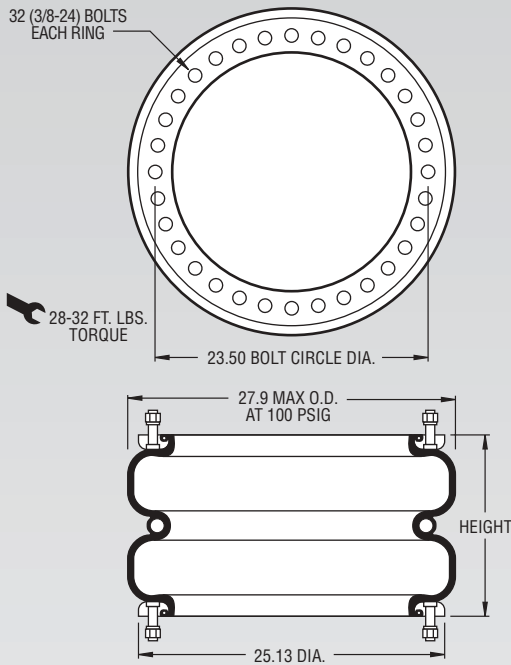

See page 12 for instructions on how to use chart.

Dynamic Characteristics at 10.5 in. Design Height (Required for Airmount isolator design only)				
Volume @ 100 PSIG = 5,094 in ³			Natural Frequency	
Gage Pressure (PSIG)	Load (lbs.)	Spring Rate (lbs./in.)	CPM	HZ
40	15,840	3,858	93	1.54
60	24,140	5,370	88	1.47
80	32,550	6,857	86	1.44
100	40,980	8,203	84	1.40

Force Table (Use for Airstroke® actuator design)						
Assembly Height (in.)	Volume @ 100 PSIG (in ³)	Pounds Force				
		@20 PSIG	@40 PSIG	@60 PSIG	@80 PSIG	@100 PSIG
12.0	5,701	6,520	13,310	20,720	28,410	36,100
10.0	4,882	8,170	16,480	25,050	33,720	42,350
8.0	3,964	9,120	18,460	27,920	37,570	47,010
6.0	2,973	9,910	19,940	30,070	40,430	51,100
4.0	1,907	10,790	21,290	31,970	42,980	54,390