

Description		Assembly Order No.
Style 19	Blind nuts, 1/4 NPT	WO1-358-7008
	Blind nuts, 1/4 NPT, bumper	WO1-358-7009
Two Ply Bellows	Blind nuts, 3/4 NPT	WO1-358-7011
	Blind nuts, 3/4 NPT, bumper	WO1-358-7012
	Countersunk steel bead rings, 1 ⁵ / ₈ bolts, nuts, washers	WO1-358-7023
	Rubber bellows only	WO1-358-0134
Assembly weight		9.8 lbs.
Force to collapse to minimum height (@ 0 PSIG).....		9 lbs.

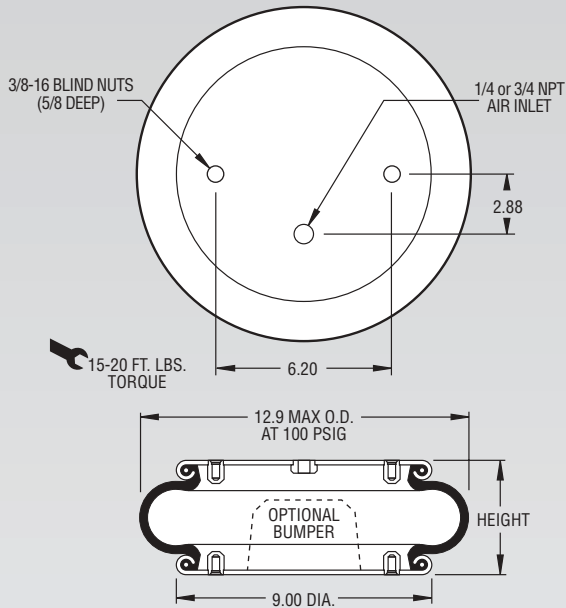

NOTE: A bead plate part is shown. This part is also available with bead rings. See pages 8-10 for explanation.

Dynamic Characteristics at 5.0 in. Design Height (Required for Airmount isolator design only)				
Volume @ 100 PSIG = 384 in ³			Natural Frequency	
Gage Pressure (PSIG)	Load (lbs.)	Spring Rate (lbs./in.)	CPM	HZ
40	2,130	1,670	166	2.77
60	3,310	2,379	159	2.65
80	4,500	3,112	156	2.60
100	5,680	3,778	153	2.55

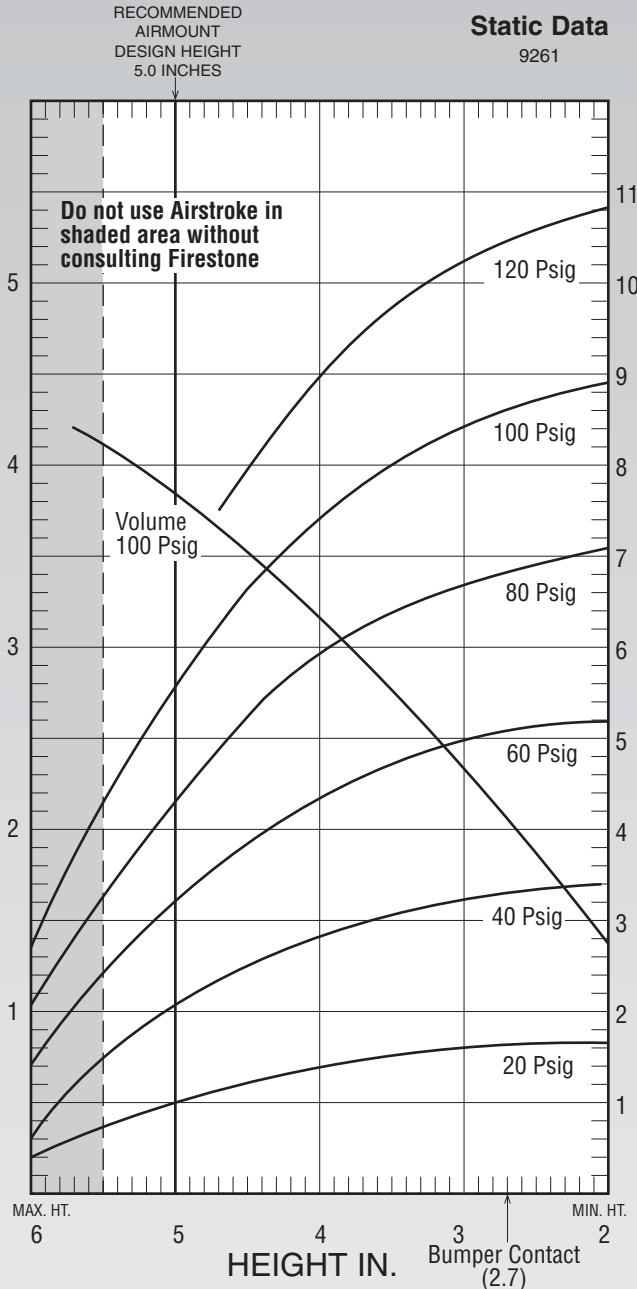

See page 12 for instructions on how to use chart.

Force Table (Use for Airstroke® actuator design)						
Assembly Height (in.)	Volume @ 100 PSIG (in ³)	Pounds Force				
		@20 PSIG	@40 PSIG	@60 PSIG	@80 PSIG	@100 PSIG
5.0	384	1,050	2,130	3,310	4,500	5,680
4.0	315	1,410	2,880	4,410	5,950	7,460
3.0	232	1,580	3,280	5,000	6,720	8,440