

Description		Assembly Order No.
Style 19-.75	Blind nuts, 1/4 NPT	WO1-358-7040
	Blind nuts, 1/4 NPT rubber bumper	WO1-358-7039
Two Ply Bellows	Blind nuts, 3/4 NPT	WO1-358-7042
	Blind nuts, 3/4 NPT rubber bumper	WO1-358-7043
Assembly weight		10.0 lbs.
Force to collapse to minimum height (@ 0 PSIG).....		15 lbs.

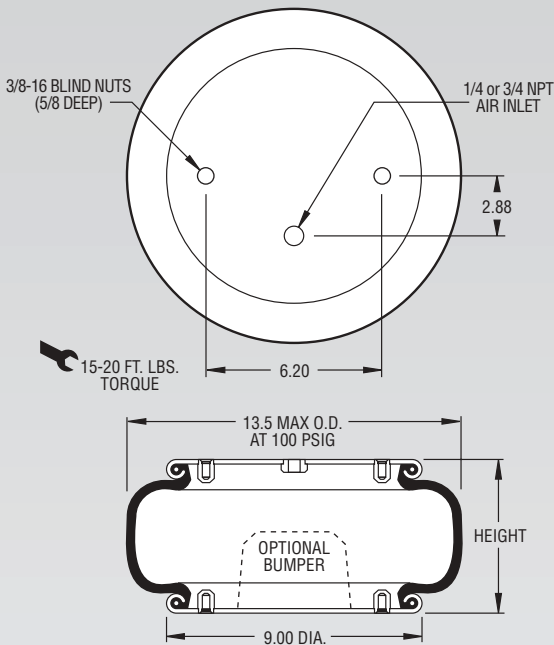

NOTE: A bead plate part is shown. This part is also available with bead rings. See pages 8-10 for explanation.

Dynamic Characteristics at 5.5 in. Design Height (Required for Airmount isolator design only)				
Volume @ 100 PSIG = 470 in ³			Natural Frequency	
Gage Pressure (PSIG)	Load (lbs.)	Spring Rate (lbs./in.)	CPM	HZ
40	1,890	1,544	170	2.83
60	2,950	2,203	162	2.70
80	4,080	2,829	156	2.60
100	5,260	3,448	152	2.53

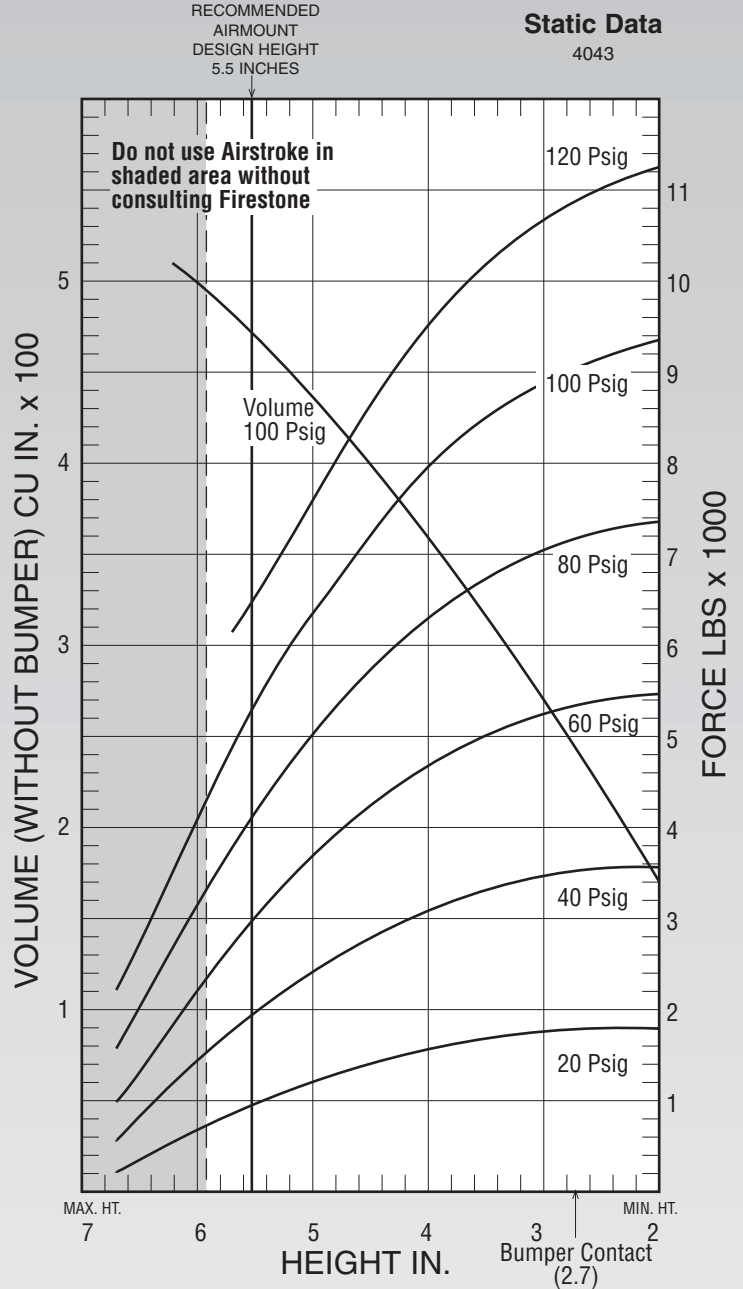

See page 12 for instructions on how to use chart.

Force Table (Use for Airstroke® actuator design)						
Assembly Height (in.)	Volume @ 100 PSIG (in ³)	Pounds Force				
		@20 PSIG	@40 PSIG	@60 PSIG	@80 PSIG	@100 PSIG
5.0	438	1,190	2,390	3,670	5,000	6,360
4.0	359	1,560	3,110	4,710	6,330	7,980
3.0	270	1,730	3,460	5,240	7,040	8,850