

Description		Assembly Order No.
Style 153-2	Blind nuts, 1/4 NPT Blind nuts, 3/4 NPT	WO1-358-8158 WO1-358-8157
Two Ply Bellows		
Assembly weight		17.1 lbs.

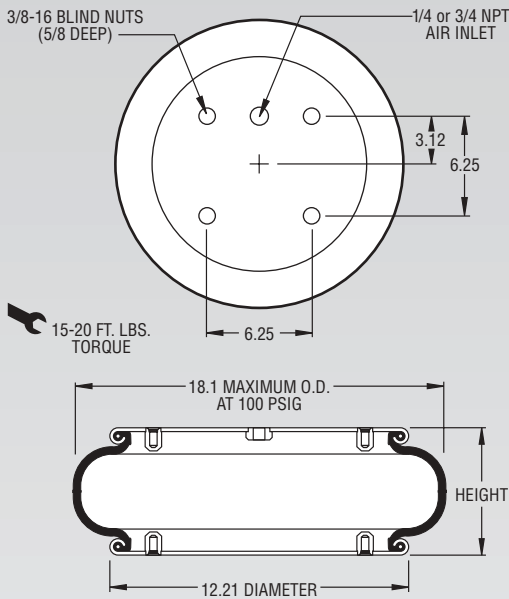

NOTE: A bead plate part is shown. This part is also available with bead rings. See pages 8-10 for explanation.

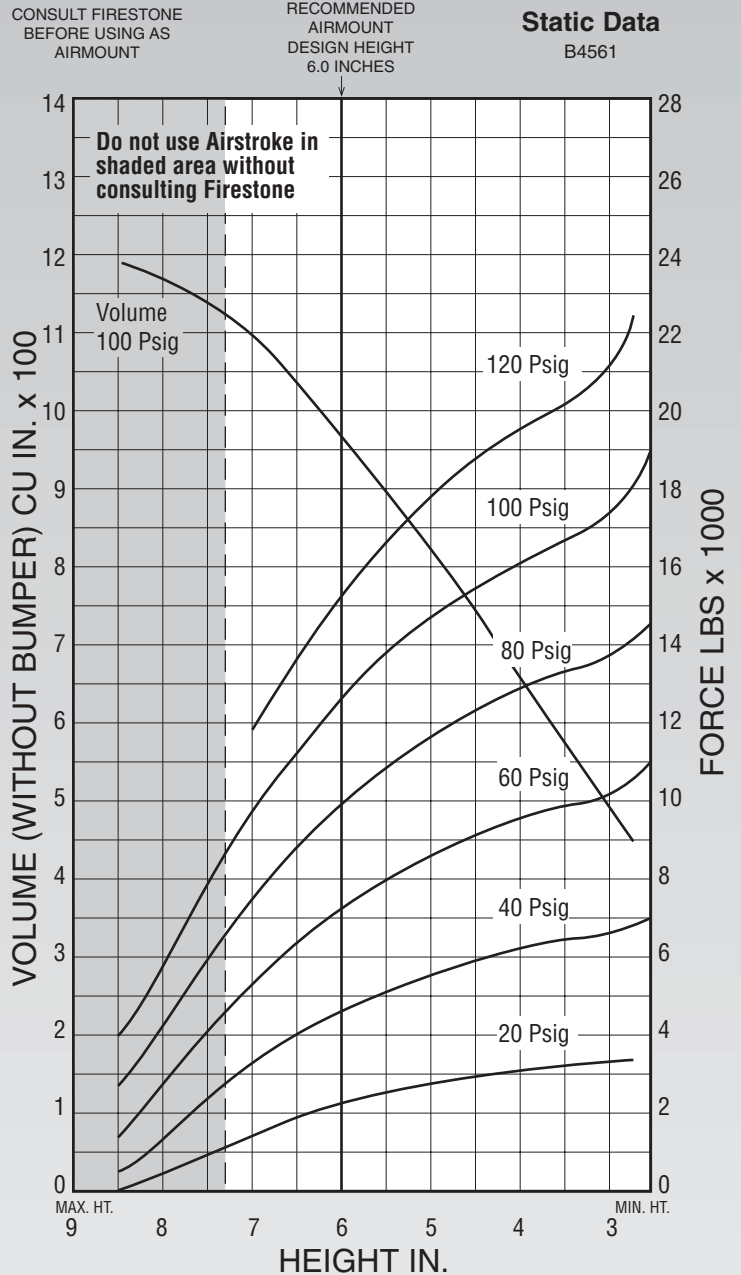

See page 12 for instructions on how to use chart.

Dynamic Characteristics at 6.0 in. Design Height (Required for Airmount isolator design only)				
Volume @ 100 PSIG = 981 in ³			Natural Frequency	
Gage Pressure (PSIG)	Load (lbs.)	Spring Rate (lbs./in.)	CPM	HZ
40	4,564	2,202	131	2.18
60	7,048	3,153	126	2.10
80	9,682	4,031	121	2.02
100	12,385	4,958	119	1.98

Force Table (Use for Airstroke [®] actuator design)						
Assembly Height (in.)	Volume @ 100 PSIG (in ³)	Pounds Force				
		@20 PSIG	@40 PSIG	@60 PSIG	@80 PSIG	@100 PSIG
8.0	1,169	425	1,260	2,566	4,038	5,636
7.0	1,094	1,423	3,210	5,194	7,334	9,528
6.0	981	2,140	4,564	7,048	9,682	12,385
5.0	840	2,676	5,476	8,458	11,440	14,471
4.0	679	3,051	6,153	9,478	12,738	15,965
3.0	510	3,219	6,609	10,069	13,550	17,218