

Description		Assembly Order No.
Style 121	Ribbed neck aluminum bead rings, 1 7/8 bolts, nuts, washers	WO1-358-7197
Two Ply Bellows	Rubber bellows only	WO1-358-5135
	Rolled Plate Assembly, 1/2 blind nuts, 3/4 NPT	WO1-358-7272
Assembly weight		16.5 lbs.
Force to collapse to minimum height (@ 0 PSIG).....		20 lbs.

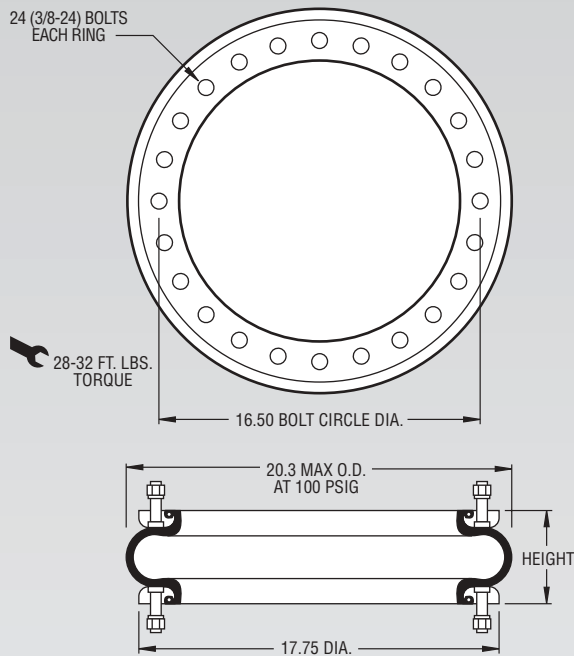

NOTE: A bead ring part is shown. This part is also available with rolled plates. See page 11 for explanation.

Dynamic Characteristics at 5.0 in. Design Height (Required for Airmount isolator design only)				
Volume @ 100 PSIG = 1,154 in ³			Natural Frequency	
Gage Pressure (PSIG)	Load (lbs.)	Spring Rate (lbs./in.)	CPM	HZ
40	6,450	4,771	161	2.69
60	10,300	6,441	148	2.47
80	14,450	8,312	142	2.37
100	18,450	10,086	139	2.31

RECOMMENDED
AIRMOUNT
DESIGN HEIGHT
5.0 INCHES

Static Data
3944

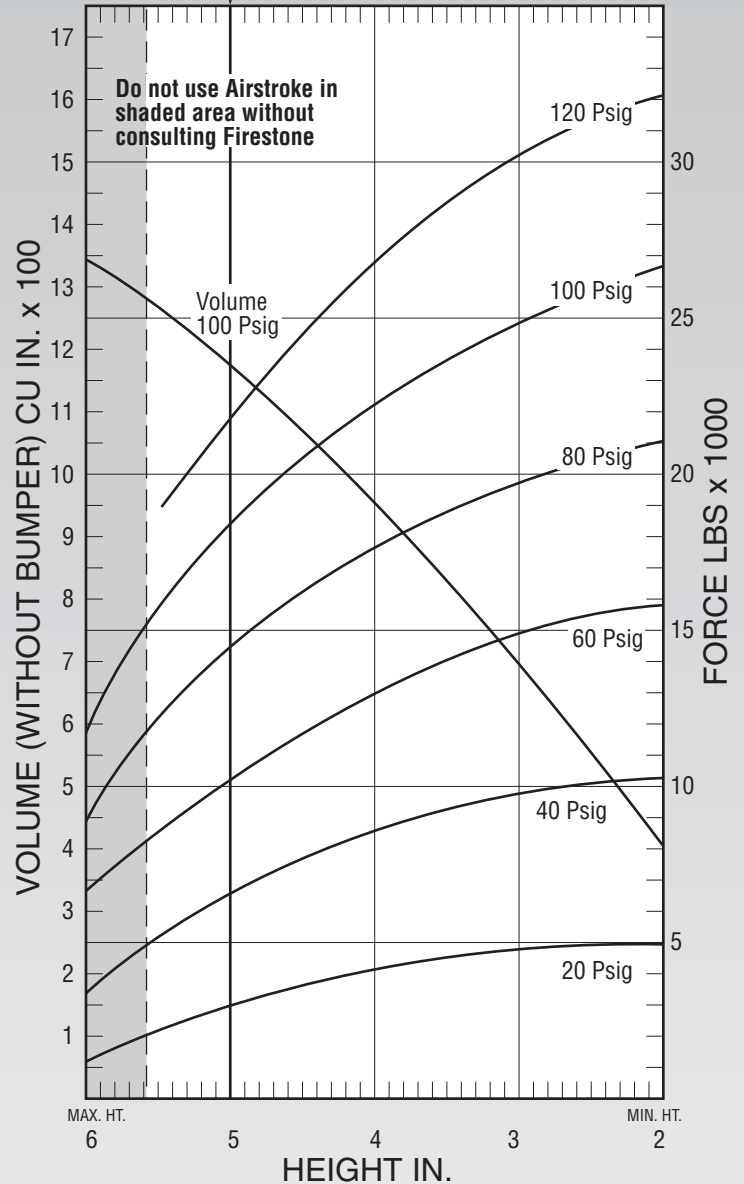

See page 12 for instructions on how to use chart.

Force Table (Use for Airstroke [®] actuator design)						
Assembly Height (in.)	Volume @ 100 PSIG (in ³)	Pounds Force				
		@20 PSIG	@40 PSIG	@60 PSIG	@80 PSIG	@100 PSIG
5.0	1,154	2,830	6,450	10,300	14,450	18,450
4.0	935	4,100	8,540	13,070	17,550	22,180
3.0	682	4,760	9,690	14,750	19,600	24,690