

Description		Assembly Order No.
Style 1M1A-0	Blind nut, 1/8 NPT, plastic stud	WO2-358-3000
Two Ply Bellows	Blind nut, 1/8 NPT, brass stud	WO2-358-3001
	Blind nut, 1/8 NPT, brass stud, stainless steel ring	WO2-358-3005
Assembly weight		0.5 lbs.
Force to collapse to minimum height (@ 0 PSIG)		20 lbs.

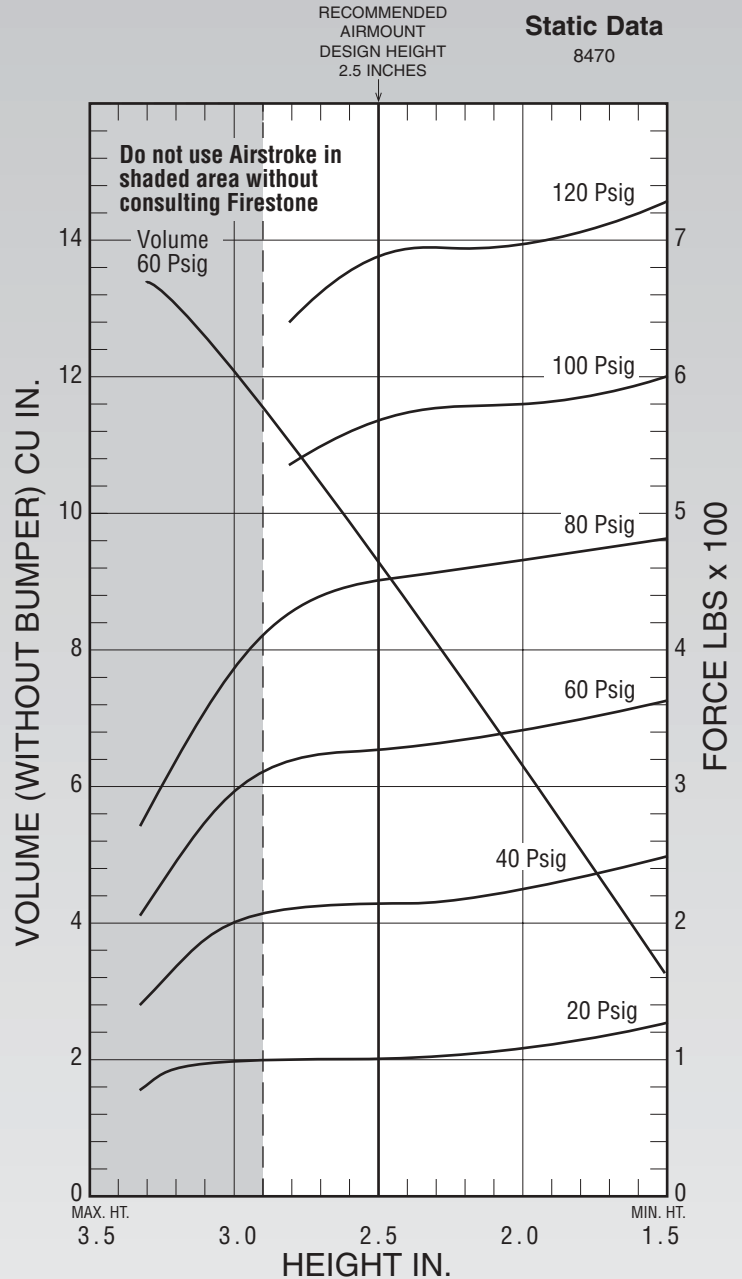
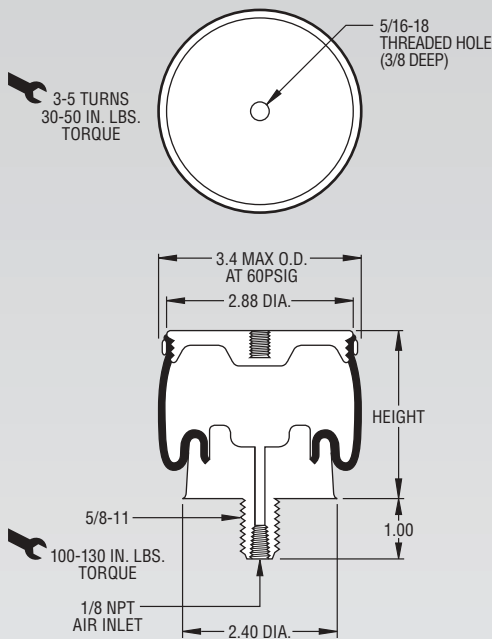

See page 12 for instructions on how to use chart.

Dynamic Characteristics at 2.5 in. Design Height (Required for Airmount isolator design only)				
Volume @ 60 PSIG = 9.2 in ³			Natural Frequency	
Gage Pressure (PSIG)	Load (lbs.)	Spring Rate (lbs./in.)	CPM	HZ
40	210	336	235	3.92
60	330	467	224	3.73
80	450	619	220	3.67
100	570	740	214	3.57

Force Table (Use for Airstroke® actuator design)						
Assembly Height (in.)	Volume @ 60 PSIG (in ³)	Pounds Force				
		@20 PSIG	@40 PSIG	@60 PSIG	@80 PSIG	@100 PSIG
2.0	6	110	230	340	460	580