

Description		Order No.
Style 160	Blind nuts, 1/4 NPT	WO1-358-7751
	Blind nuts, 3/4 NPT	WO1-358-7752
Two Ply Bellows	Socket head aluminum bead rings (bolts, nuts, washers not included-use 1/4 cap screws)	WO1-358-7592
Assembly weight		3.0 lbs.
Force to collapse to minimum height (@ OPSIG)		140 lbs.

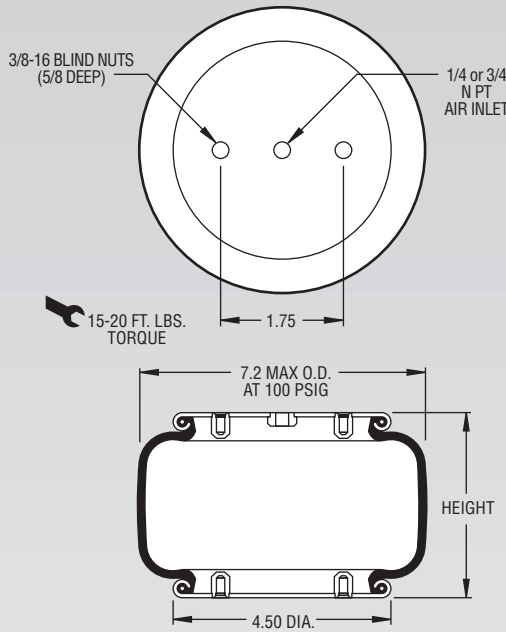

NOTE: The bellows extends beyond the bead plates at minimum height.

NOTE: A bead plate part is shown. This part is also available with bead rings. Bolts are not included. See pages 8-10 for explanation.

Dynamic Characteristics at 5.5 in. Design Heights (Required for Airmount isolator design only)				
Volume @ 100 PSIG = 128 in ³			Natural Frequency	
Gage Pressure (PSIG)	Load (lbs.)	Spring Rate (lbs./in.)	CPM	HZ
40	650	327	133	2.22
60	1010	464	127	2.12
80	1390	601	124	2.07
100	1760	737	121	2.02

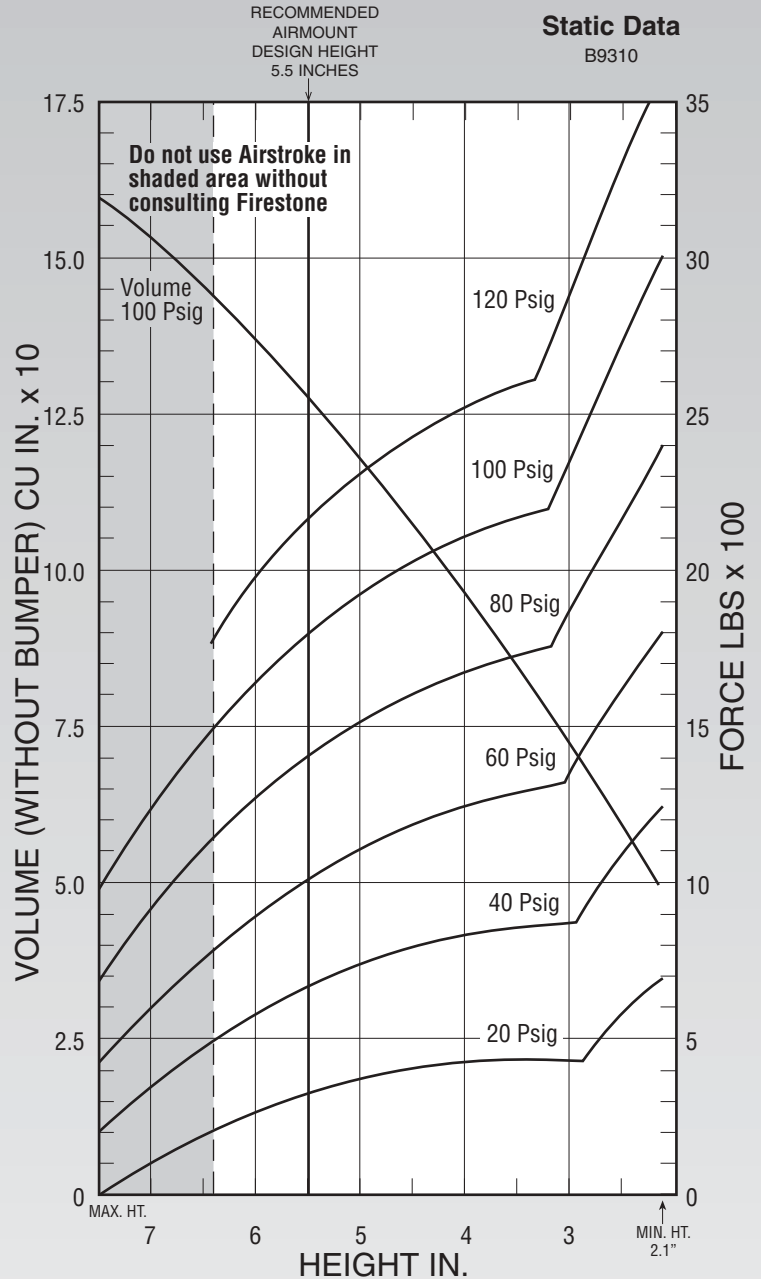

See page 12 for instructions on how to use chart.

Force Table (Use for Airstroke [®] actuator design)						
Assembly Height (in.)	Volume @ 100 PSIG (in ³)	Pounds Force				
		@20 PSIG	@40 PSIG	@60 PSIG	@80 PSIG	@100 PSIG
6	137	240	560	900	1250	1620
5	118	340	710	1100	1500	1920
4	97	400	810	1240	1670	2110
3	73	440	870	1360	1870	2390